

CAUTIONS

1. Remove the vacuum from the pool prior to super chlorinating the water and do not re-install it for a minimum of four hours.
2. Do not operate the vacuum cleaner if excessive amounts of debris or large leaf clusters are in pool.
3. Do not allow swimmers in the pool while the vacuum cleaner is operating.
4. Keep skimmer and pump strainer baskets clean when operating the vacuum.
5. Keep hose sections straight when cleaner is out of pool.

PREPARATIONS

- Clean pool, removing any debris.
- Backwash filter or clean filter element.
- Clean out all strainer baskets.
- Adjust return inlet flow direction downward at approximately 45°

FIG.1

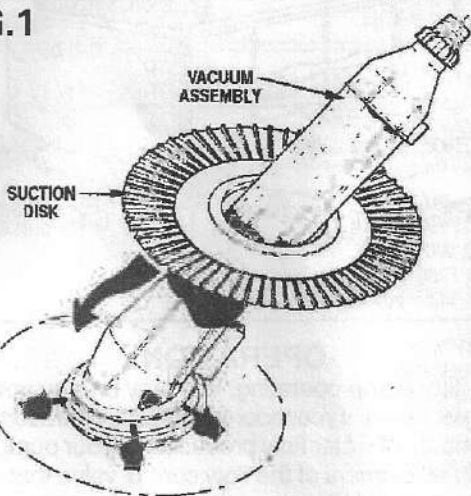

HOSE WEIGHTS

POOL VACUUM RING

FIG.2

HOSE SECTIONS
1-1/2" X 3' LONG

VACUUM ASSEMBLY

RUB BAR

FLOW CONTROL VALVE

SUCTION DISK

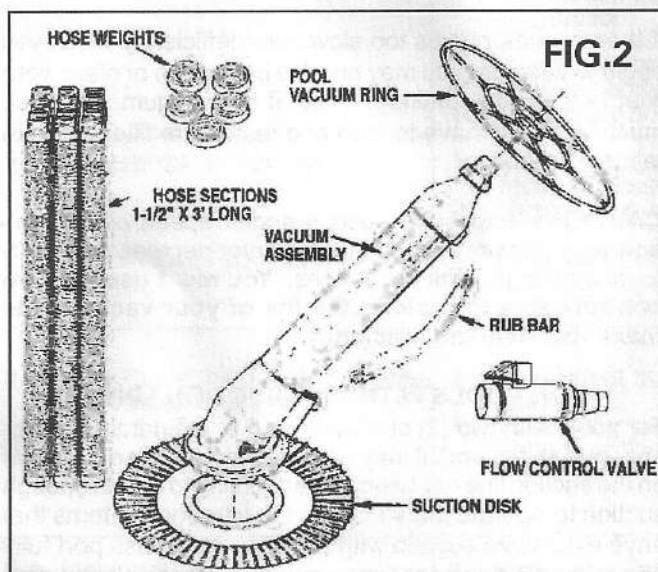

COMPONENTS ASSEMBLY

With smooth side of suction disk facing downward, slip over top of vacuum assembly, stretching over weight arm and into slot indicated by arrows. as shown above. Install

in rub bar cap and vacuum housing strap receiver as shown below. SEE FIG.S 1 & 2.

VACUUM HOSE

Join hose sections by inserting male cuff of one hose into the female cuff of another. Hose length should be pool length or diameter plus one hose length. SEE FIG. 3.

FIG.3

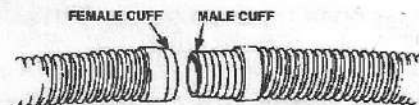

CONNECT HOSE TO VACUUM

Place pool vacuum ring onto end of the vacuum assembly. push female cuff end of hose onto the vacuum outlet port. Place vacuum into pool. SEE FIG. 4.

FIG.4

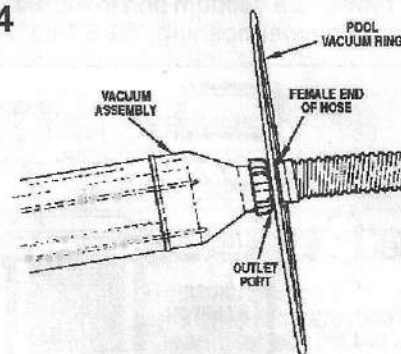

INSTALL FLOW CONTROL VALVE

Insert the male cuff end of hose into the large end of the flow control valve. SEE FIG. 5

FIG.5

SUCTION BYPASS PORT

FLOW CONTROL VALVE

MALE END OF HOSE

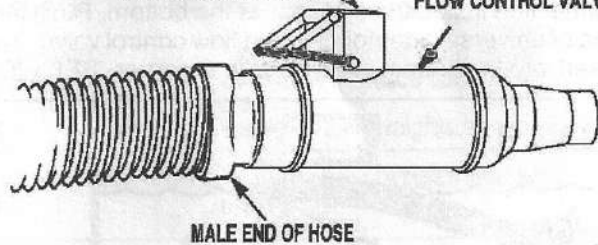

The following four illustrations show different methods for connecting a vacuum hose depending on your type of pool, skimmer or suction port. Select the one similar to your pool and suction port. A universal adaptor is provided for use as shown in illustrations B and D. For illustration 'C', purchase an elbow adaptor from your pool dealer to fit your suction port and that will also receive the small end of the automatic flow control valve. NOTE: Flow control valve must be installed so that that bypass port is always below the pool water level.

IMPORTANT INFORMATION

When connecting the vacuum hose to the suction port of your skimmer, **DO NOT route the hose over the pool wall.** Your pump could lose its prime if the vacuum rises far enough on the wall to allow air to enter the hose.

FOR BEST RESULTS, connect the hose with flow control valve directly to the skimmer faceplate suction port. Be sure to lower the skimmer lid to the top of the skimmer basket before operating your pump (see Fig. A).

IF YOUR SKIMMER FACEPLATE DOES NOT HAVE A VACUUM PORT, or you choose not to use it, route the hose with flow control valve and adaptor through the skimmer opening to the suction port as shown in Figs B or C in this owner's guide.

EXPEL AIR FROM HOSE AND CONNECT TO VACUUM OUTLET

With pump running, position end of hose against pool return outlet to blow out any air in the hose. While holding end of hose below pool water level, attach to your pool or skimmer suction port.

SKIMMER VACUUM PORT

This skimmer provides a vacuum port in the skimmer face frame below the skimmer opening. SEE FIG. A.

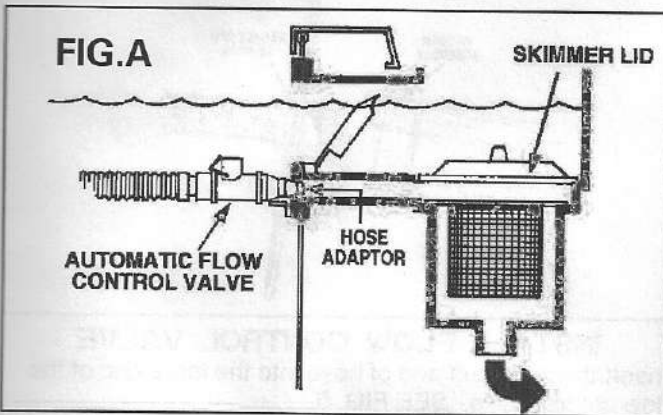

INSIDE SKIMMER OUTLET

This skimmer provides either a threaded or slip socket connection inside the skimmer at the bottom. Push larger end of universal adaptor onto the flow control valve. Then, insert into the bottom outlet inside the skimmer. SEE FIG. B.

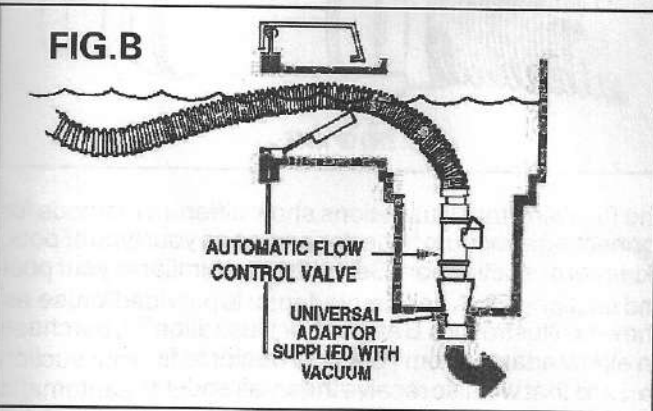

SKIMMER VACUUM PLATE

This skimmer is provided with a vacuum plate with a suction hose port in the center for attaching your vacuum hose. Insert the elbow adaptor (not provided) onto the flow control valve, then onto the vacuum plate outlet. SEE FIG. C.

VACUUM OUTLET (IN-GROUND POOL)

If your pool is provided with a vacuum port outlet in the pool

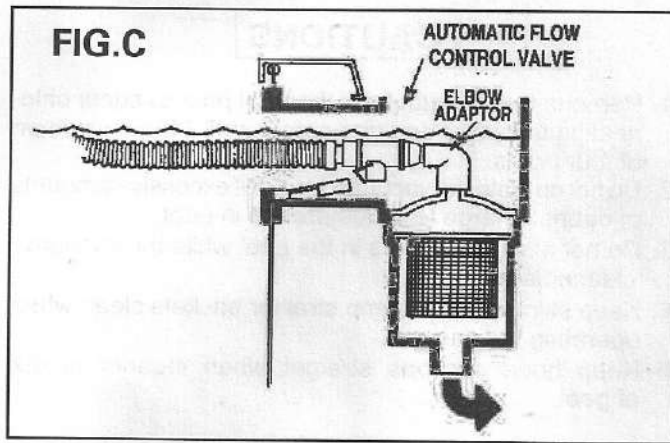

wall, connect the hose to this port as follows. Push larger end of universal adaptor onto the flow control valve. Then, insert into the wall vacuum outlet. SEE FIG. D.

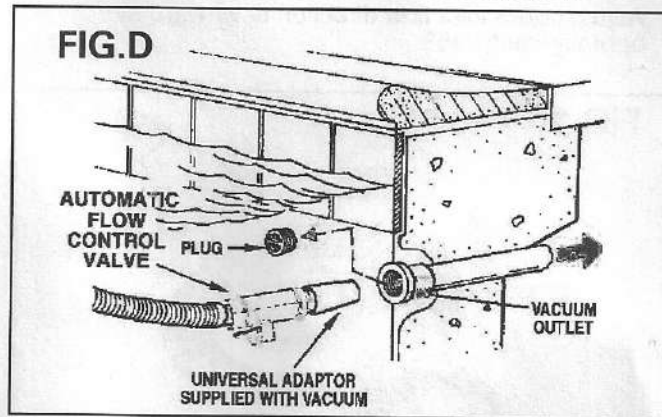

OPERATION

With the filter pump operating, you may or may not notice a pulsating vibration of your pool vacuum. Its operation depends on the amount of water flow produced by your pump, and the automatic adjustment of the flow control valve that regulates water flow to the skimmer suction port.

If the vacuum moves too slow and inefficiently when you begin to vacuum, you may need to backwash or clean your filter before you continue. Also, if the vacuum slows too much, you may have to stop and restart the filter pump to resume operation.

CAUTION: Excessive suction and/or speed could damage your vacuum's components and/or decrease its ability to maneuver in confined spaces. **You must use the flow control valve to prolong the life of your vacuum and maximize cleaning efficiency.**

FOR POOLS WITH TWO SUCTION LINES

For pools with two (2) suction lines (i.e. maindrain & skimmer, or 2 skimmers), it may be necessary to close the valve on the suction line not used for vacuuming to obtain enough suction to operate the vacuum. On filtration systems that have excessive suction with the suction bypass port fully open, throttle down the vacuum by progressively opening up the second suction line valve.

INSTALL HOSE WEIGHTS

See Fig.6

Depending on your pool's depth and water temperature, your vac may require use of hose weights to help it to

maintain constant contact with the pool's bottom. Add hose weights as shown using a trial and error method (observe the vacuum's operation) to determine the best number of weights to use, and the most effective location for them.

CHECK FILTER FLOW

As your vacuum cleaner removes sediments from the pool

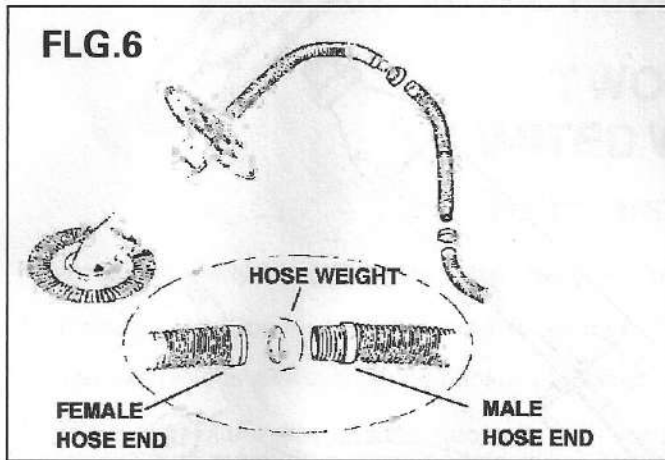

floor, you may notice your vacuum operating slower than normal with a reduction of flow from the return inlet as your filter becomes dirtier. **Keep a check on your filter pressure and backwash the filter or clean the filter element when required.**

SERVICING

Your vacuum may become inoperable for several reasons. Check the "Troubleshooting" chart to determine the cause and remedy. If your vacuum becomes clogged with debris, shut off pump. Lift the vacuum cleaner out of the pool and examine the underside intake. Pull out the debris and refer back to "Expel Air from Hose" and restart the filter and vacuum operation.

VACUUM WINTER STORAGE

Remove your vacuum from the pool and dry completely. Disassemble the hose sections and store in the original box. **Never store the hose in a coiled position as it may retain a curved shape, not allowing the vacuum to operate efficiently.** Store the vacuum so that the suction disk lays flat, or remove the disk and store it in a flat position. Store all parts indoors.

TROUBLESHOOTING POOL VACUUM CLEANER

PROBLEM	POSSIBLE CAUSE	REMEDIES
1. Vacuum moves too slow or not moving at all.	1 - Vacuum intake clogged with debris. 2 - Flow control bypass port stuck in open position. 3 - Filter is dirty. 4 - Skimmer or pump strainer baskets are clogged with debris. 5 - Crack in hose. 6 - Clogged pump impellor. 7 - Excessive debris on pool floor. 8 - Insufficient pump flow due to obstruction. 9 - Air leak at skimmer face plate causing water to drain from skimmer body. 10 - Too many hose weights	1 - Remove debris. 2 - Remove obstruction or replace spring(s) if broken or missing. 3 - Clean filter element or backwash filter. 4 - Empty baskets. 5 - Replace hose section. 6 - Remove debris. 7 - Manually remove debris from floor. 8 - Remove obstruction. 9 - Tighten skimmer face plate screws or replace face plate gaskets. 10 - Remove hose weights as required.
2. Vacuum moves too fast.	1 - Flow control valve's bypass port stuck in closed position. 2 - Excessive pump flow.	1 - Clean suction bypass port and hinge mechanism. 2 - Restrict flow.
3. Vacuum loses contact with pool bottom.	1 - Flow control bypass port stuck in open position. 2 - Vacuum too buoyant for pool depth.	1 - Remove obstruction or replace spring(s) if broken or missing. 2 - Add hose weights as required.
4. Vacuum cleans one end of pool. Won't clean entire pool.	1 - Insufficient number of hose sections. 2 - Pool water too cold. Causes hose to stiffen.	1 - Add more hose. 2 - Pool water should be a minimum 60°F. Increase flow by closing suction control slide. Remove from pool and store for winter.
5. Vacuum turns over.	1 - Excessive flow currents in pool. 2 - Contacting an obstruction in pool. 3 - Hose too long. 4 - Swivel jammed with debris.	1 - Adjust return fitting flow downward. 2 - Remove obstruction if possible, or restart vacuum at a new position. 3 - Remove hose one section at a time. 4 - Rotate until swivel moves freely.

EXPLODED VIEW POOL VACUUM CLEANER

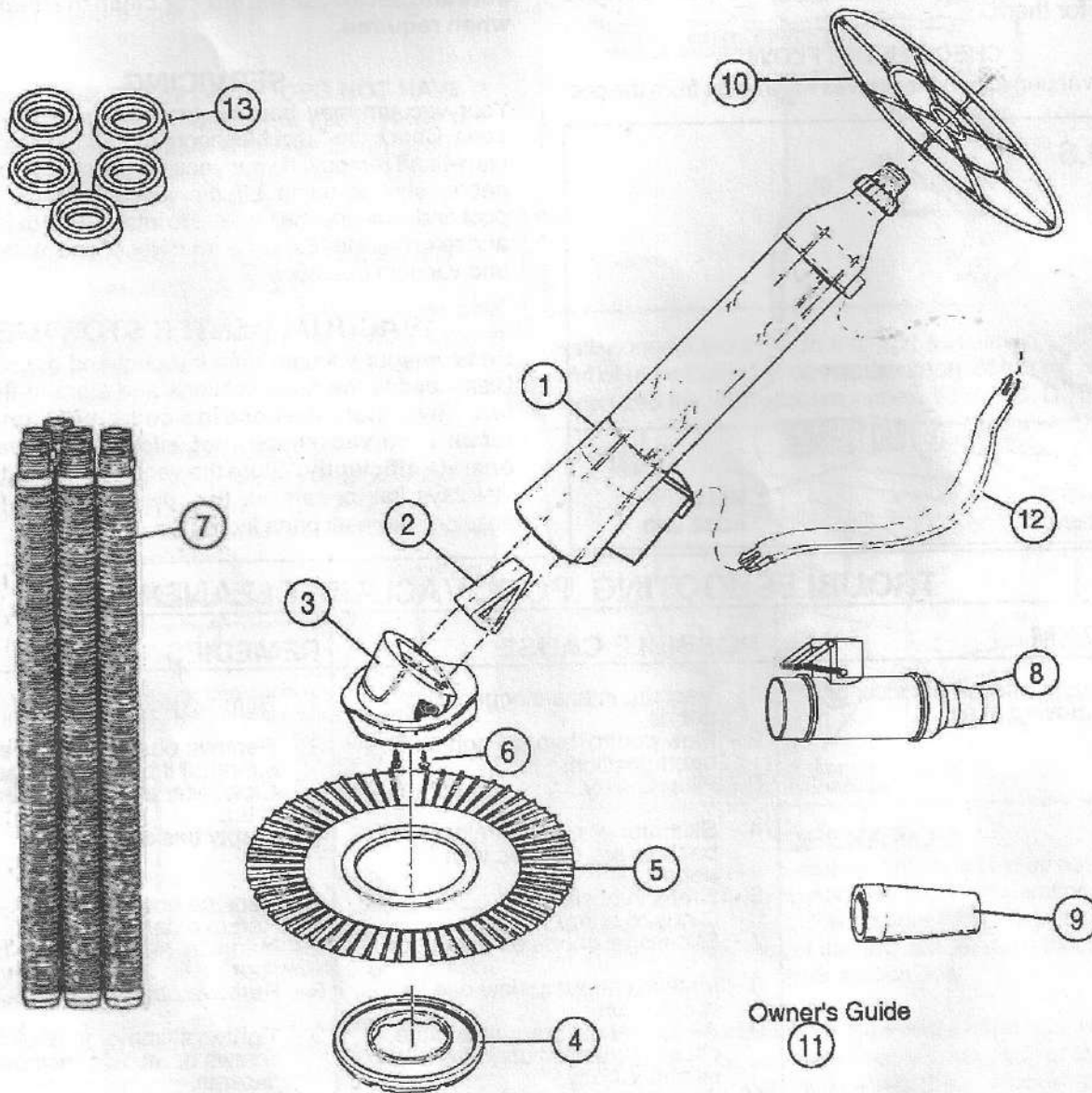

Owner's Guide

11

PARTS LIST

ITEM	PART #	QTY	DESCRIPTION
1	1121-2046	1	Vacuum Body Assembly
2	340-2062	1	Driver
3	340-2718	1	Vacuum Head
4	348-1047	1	Suction Pad
5	340-2066	1	Suction Disk
6	330-1253	2	#8 x 3/4" Screws
7	346-1079	15	1-1/2" x 3' Hose
8	1107-1681	1	Flow Control Valve
9	340-2108	1	Universal Adaptor
10	340-2112	1	Pool Vacuum Ring
11	365-2084	1	Owner's Guide
12	341-1412	1	Rub Bar
13	340-2201	5	Hose Weight